



TESI High Energy Ignition System can be used to directly ignite oil and gas burners. As a Class 3 Igniter, the output energy of up to 10 Joules provides powerful sparks with a rate of 24 sparks/sec. as a standard.

The circuit is provided with a regulator on the main inlet so that the sparks rate can be finely adjusted (by TESI accordingly to customer request). This circuit is also able to monitor :

- Transformer temperature and prevent any damage due to over temperature;
- Transformer max current, capacitor max voltage, spark down rate(<2);
- Max working time.

Tesi's High Energy system can be utilized in both Safe and Hazardous areas. The main components for both applications consist of a Power Pack unit installed in an enclosure box suitable for wall mounting, a High Energy rod complete with a replaceable spark tip and an high voltage connecting cable.

Standard production consists of a rigid ignition rod, but a flexible configuration can be realized for tilting tangential applications.

High reliability

The powerful sparks ensure ignition in all conditions and environments with no risk of failure due to contaminants or humidity.

Low maintenance

Self-cleaning spark tips guarantee successful ignition. In fact the high power of the spark cleans the surface of the tip during every ignition.

Easy & Fast maintenance

Spark tips screw onto the end of the rod can be replaced quite easily, reconditioning the system very quickly and reducing maintenance costs.

Accessories & spare parts

A wide range of accessories and spare parts on stock can be quickly supplied and allows for customization of the systems according to customer specification.

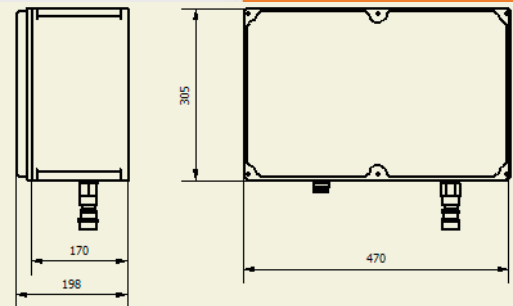
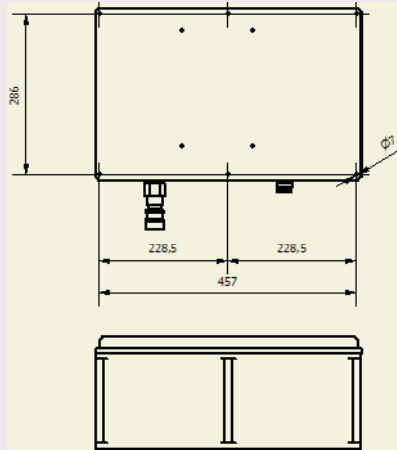
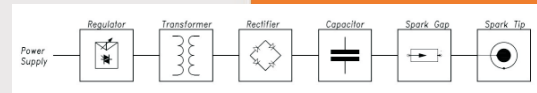

TECHNICAL DATA

INPUT VOLTAGE:	115 or 230 VAC 50 Hz (60 Hz on demand)	
INPUT CURRENT:	MAX 10 A	RMS CURRENT ~ 6 A (at 24 Sp/Sec)
INPUT POWER:	According Sparks Rate	700W (at 24 Sp/Sec)
OUTPUT VOLTAGE:	1400 V	+/- 10%
OUTPUT ENERGY:	10 J	Each Spark +/- 10%
WORKING TIME:	Not for continuous service According to Sparks Rate	Max 1 minutes ON/Min 2 minutes OFF/Max 3 subsequent sequences (at 24 Sp/Sec)
SPARK FREQUENCY:	24 spark/second	
WORKING TEMPERATURE:	-5 ÷ + 60°C	On request -30 ÷ + 60°C
PROTECTION GRADE:	IP66	On request other options

DATA SUBJECT TO CHANGE WITHOUT NOTICE

HE-TIP Rev.01



TESI srl
Sede Operativa: Via Piave 20/11 - 20080 Vermezzo (Milano) Italy
Tel. +39 02 944 05 01 - Fax +39 02 944 90 87
e-mail: info@tesigroup.com - www.tesigroup.com



شرکت آلاپرداز محیط

تهران - خیابان آزادی - بین خیابان شادمهر و بزرگراه یادگار امام - شماره ۴۱۷ - واحد ۵

E-mail: info@apm-co.ir تلفن: ۰۲۱-۶۶۰۲۸۱۷۲-۵
Website: www.apm-co.ir فکس: ۰۲۱-۶۶۰۲۰۵۰۹